

KESKINLER ELEKTRONİK

HSD Hybrid Step Servo Motor Driver
JK-HSD57
 MicroSteps Setting:800~25600 DC: +24~+60V

Products Image

JK-HSD57 Hybrid Servo Driver

Motor Sel	SW7	SW8
42	on	on
57	off	on
60	on	off
Default(86)	off	off

VDC: +24V~+60V

Pulse/rev	SW1	SW2	SW3	SW4
Default	on	on	on	on
800	off	on	on	on
1600	on	off	on	on
3200	off	off	on	on
6400	on	on	off	on
12800	off	on	off	on
25600	on	off	off	on
500	off	off	off	on
1000	on	on	on	off
2000	off	on	on	off
3600	on	off	on	off
4000	off	off	on	off
5000	on	on	off	off
7200	off	on	off	off
8000	on	off	off	off
10000	off	off	off	off

SW5: Motor DIR, off=CCW, on=CW
 SW6: Mode Sel, off=FOC, on=PM

Overview

- Without losing step, High accuracy in positioning.
- Accelerate and decelerate control inside, Great improvement in smoothness of starting or stopping the motor.
- Small vibration, Smooth and reliable moving at low speed.
- The optocoupler isolates the differential signal input.
- Over current, over voltage and over position error protection.
- The impulse response frequency can reach up to 200KHz.
- Subdivision Settings (within 800~ 25600)

Features

Input voltage	24~60VDC
Output current	4.5A
Pulse frequency	0~200KHz
MicroSteps	16 MicroSteps
Signal current	7~20mA
Using environment	0 ~ 70 °C, avoid dust and corrosive gas
Storage environment	-20~+80°C, avoid direct sunlight
Heavy volume	280g (Does not contain the packaging)

Generally speaking, the power supply voltage is a little higher, and the motor's high-speed performance will be relatively low when the power supply voltage is good. It is suggested that the normal operating speed range is 36V above power supply for high-speed operation.

Encoder signal

Symbol	Name	Wiring color
EB+	Encoder phase B +	/
EB-	Encoder phase B -	/
EA+	Encoder phase A +	/
EA-	Encoder phase A -	/
VCC	Encoder power	5V
GND	Encoder power ground	0V

Motor and power

Symbol	Name	Remark
A+	Phase A+	/
A-	Phase A-	/
B+	Phase B+	/
B-	Phase B-	/
VCC	Input Power +	+24V~60V
GND	Input Power-	0V

Control Signal

Symbol	Name	Remark
PUL+	Pulse signal +	Compatible with 5/12/24V
PUL-	Pulse signal -	
DIR+	Direction signal+	Compatible with 5/12/24V
DIR-	Direction signal-	
ENA+	Enable signal +	Only connected when used
ENA-	Enable signal -	Only connected when used

ALM Signal

Symbol	Name	Remark
ALM+	Positive alarm signal	Only connected when used
ALM-	Negative alarm signal	Only connected when used

Changzhou Jkongmotor Co., Ltd

Dial Code Switch Setting

SW5 sets the motor direction. When it is OFF, the motor rotates counterclockwise to CCW. When it is ON, the motor rotates clockwise to CW.

SW6 function mode selection. When OFF, the drive is space vector control mode is FOC. When it is on, the drive point movement mode is PM.

MicroSteps Setting

RPM	Default	800	1600	3200	6400	12800	25600	500	1000	2000	3600	4000	5000	7200	8000	10000
SW1	ON	OFF	ON	OFF	ON	OFF	ON	OFF	ON	OFF	ON	OFF	ON	OFF	ON	OFF
SW2	ON	ON	OFF	OFF	ON	ON	OFF	OFF	ON	ON	OFF	OFF	ON	ON	OFF	OFF
SW3	ON	ON	ON	ON	OFF	OFF	OFF	OFF	ON	ON	ON	ON	OFF	OFF	OFF	OFF
SW4	ON	ON	ON	ON	ON	ON	ON	ON	OFF	OFF	OFF	OFF	OFF	OFF	OFF	OFF

Control Signal Connection

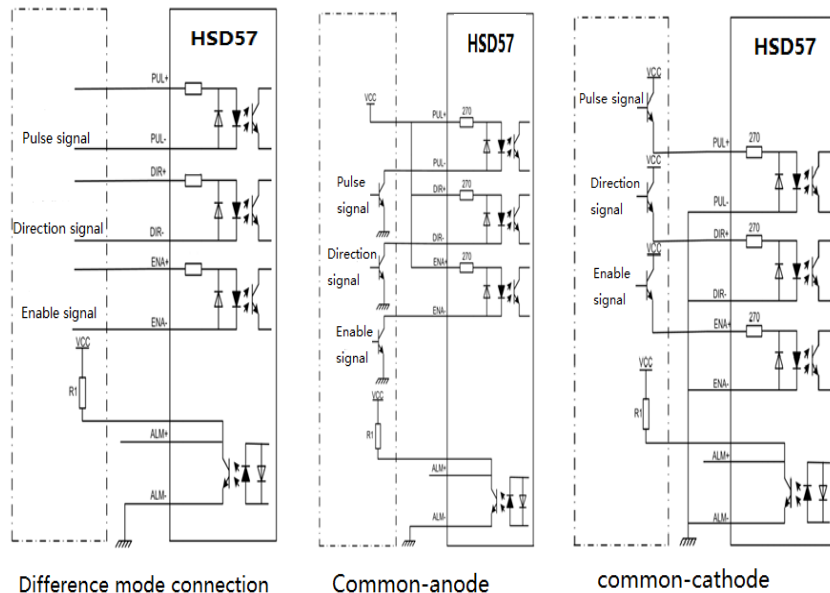





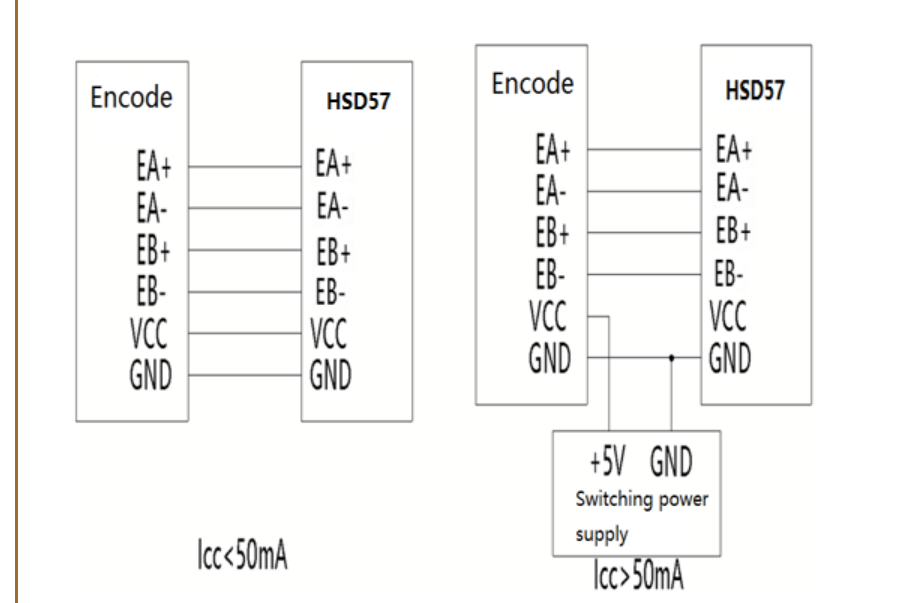

Remarks: VCC compatible 5/12/24V

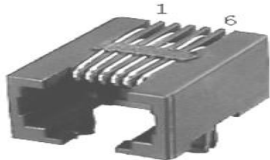
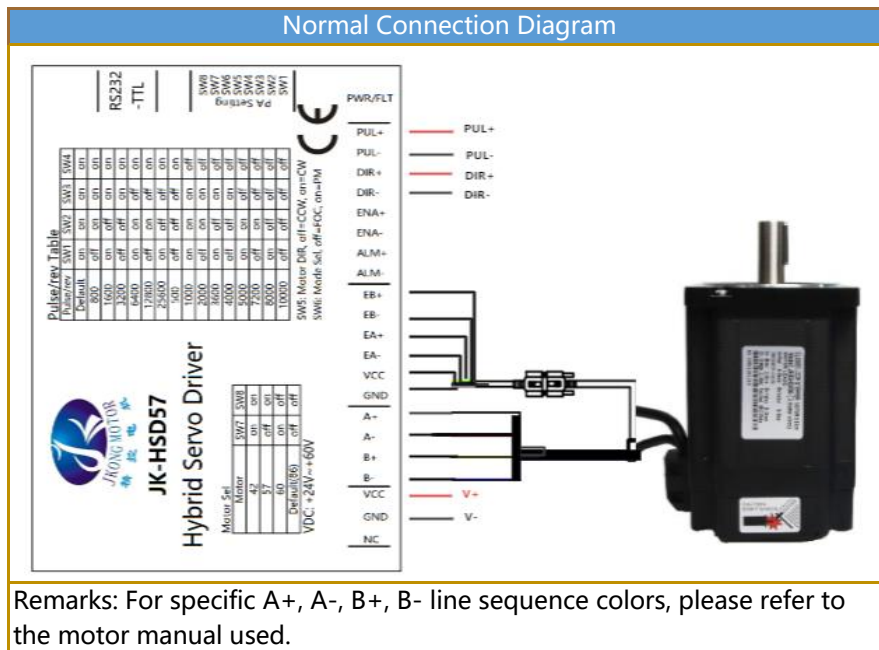
Control Signal Input Terminal



RS232-TTL Interface Pin Definition			
Terminals no.	Symbol	Designation	Instructions
1	NC	/	/
2	+5V	Positive-supply	/
3	TxD	RS232-TTL sender	/
4	GND	Power ground	/
5	RxD	RS232-TTL receiver	/
6	NC	/	/

LED status indication		
Number of flashes	Red indicator flashing wave pattern	Fault description
1		Driver overcurrent
2		Driver internal voltage reference error
3		Error uploading drive parameters
4		Driver supply voltage exceeds maximum
5		Motor phase missing alarm
6		Motor phase missing alarm

- ### Frequently Questions And Troubleshooting
- 1, Power light is off, while the power is on**
 - Input power failure, please check the power line, to see if the voltage is too low or not.
 - 2, Red light alarms when offering power**
 - Please check if the motor feedback signal line and motor power cable are connected or not.
 - Please check if driver's input voltage is too high or too low.
 - 3, The red light alarms after running a small angle**
 - Please check if motor's phase wires are connected correctly or not. If not, please double check motor's wires & driver's corresponding phase sequence are correctly connected.
 - In the driver configuration parameters, if the number of wires for motor encoder is the same as the actual parameters for connected motor or not? If not, please reset.
 - Please check if pulse's input speed is higher than motor's rated speed or not? If so, it will cause position's out of tolerance.
 - 4, The driver doesn't run after offering input pulse**
 - Please check if wiring of pulse input terminals for the driver is reliable or not?
 - Please check if input mode of the step servo drive system configuration is the same as pulse's input method or not.
 - Please check if the motor's Enable signal is on or off.

